

POWER CROSSING BEHAVIOUR OF LINE CARD PROTECTION

A. Bremond

1 - INTRODUCTION

The purpose of this document is to explain the behaviour of LCP 150S/1511/1512 devices during the coupling between a telecommunication line and a mains line.

2 - TEST DIAGRAM

Figure 1 shows the test diagram. The mains 220 V 50 Hz is applied to the test assembly through an isolation transformer. A relay driven by a mono-pulse generator allows the conducting time to be adjusted. The current through the device is adjusted by a series resistor.

Figure 1 : Test Diagram

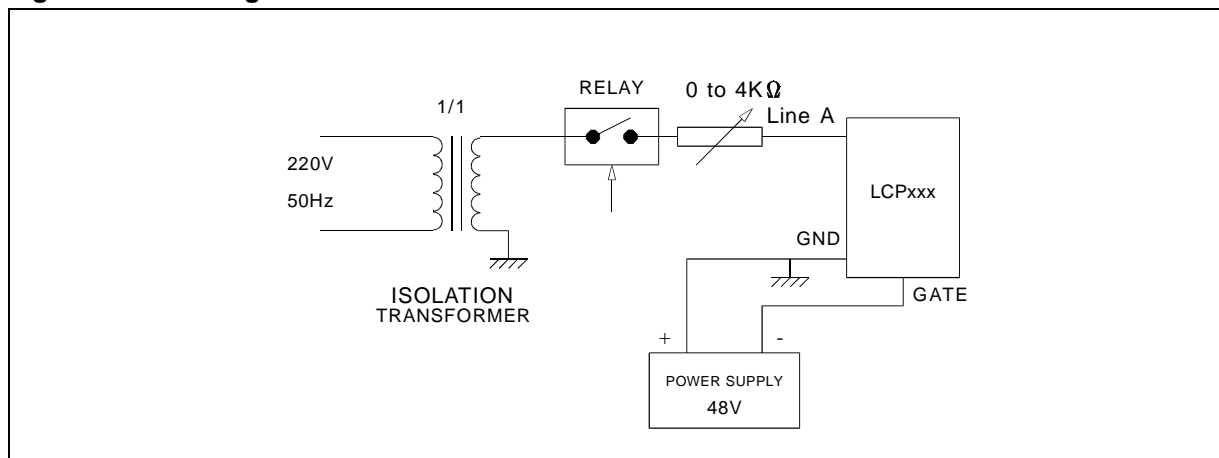

3 - MEASUREMENTS

During the tests three kinds of behaviour occur :

a) As shown in figure 2 the device acts as a

clamping device (non-firing) due to the small value of the current which never exceeds the latching current of the structure.

Figure 2 : Voltage and current for a non-firing device

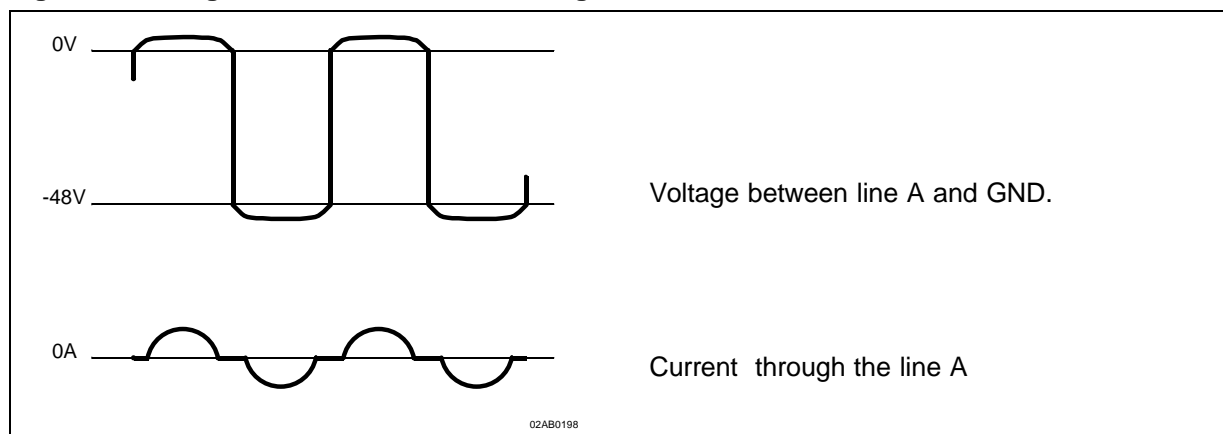

APPLICATION NOTE

b) In the second operating region the LCPxxx fires and the piece under test is still functional after 15 minutes.

- Figure 3.1 shows the start of the firing (the peak of the current wave through the device is just over the latching limit).

- In figure 3.2 the amplitude of the current wave through the device is greater than in the precedent case, so the device is well fired after a few hundred microseconds.

c) In the third operating region the device has been destroyed in a time depending on the current through the LCPxxx.

Figure 3 : Voltages for a firing device

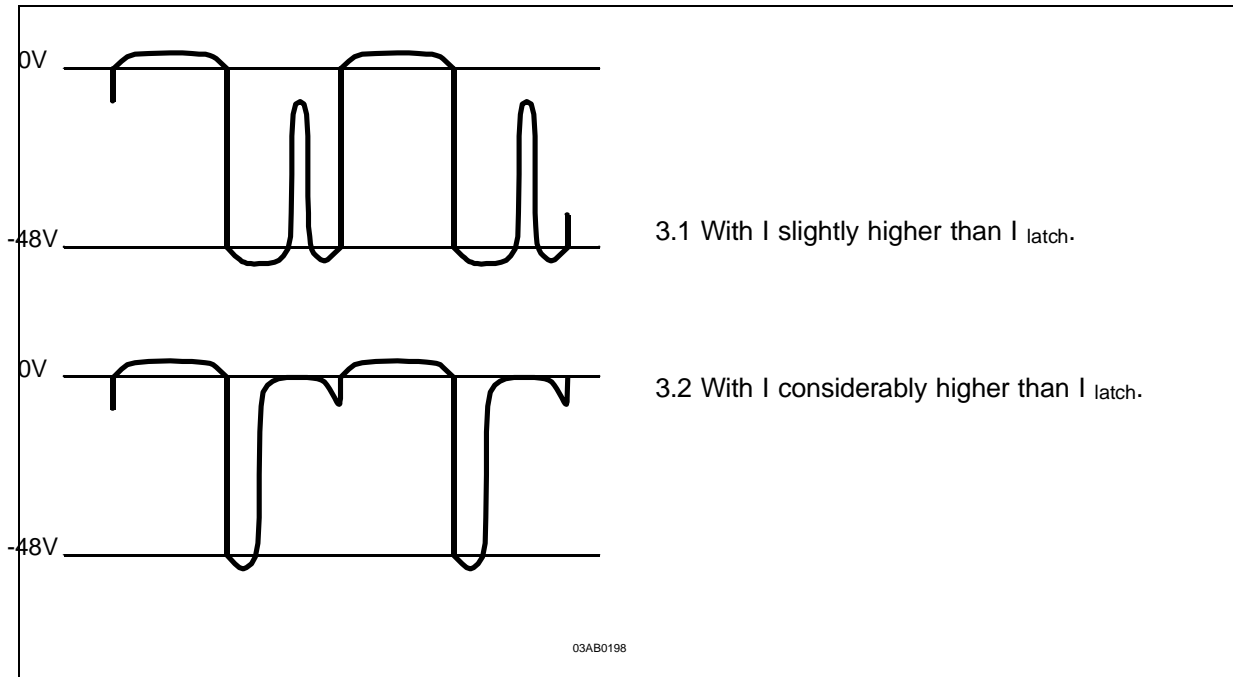

4 - ANALYSIS

OPERATING REGION	LCP 150	LCP 1512	LCP 1511
A/clamping	0 to 70 mA *	0 to 70 mA *	0 to 70 mA *
B/non destructive region	0.07 to 2 A *	0.07 to 1.2A*	0.07 to 0.8A *
C/destructive region	Over 2 A *	Over 1.2 A *	Over 0.8 A *
* RMS current			

Table 1: Operating Region Definition

Table 1 shows the range of the three operating regions, while figure 4, which illustrates region C, allows us to determine the destruction time limit of each device versus the current through the structure (RMS current at 25°C).

**Figure 4 : Characteristics of Region C
(With $V_{gate} = -48 V$)**

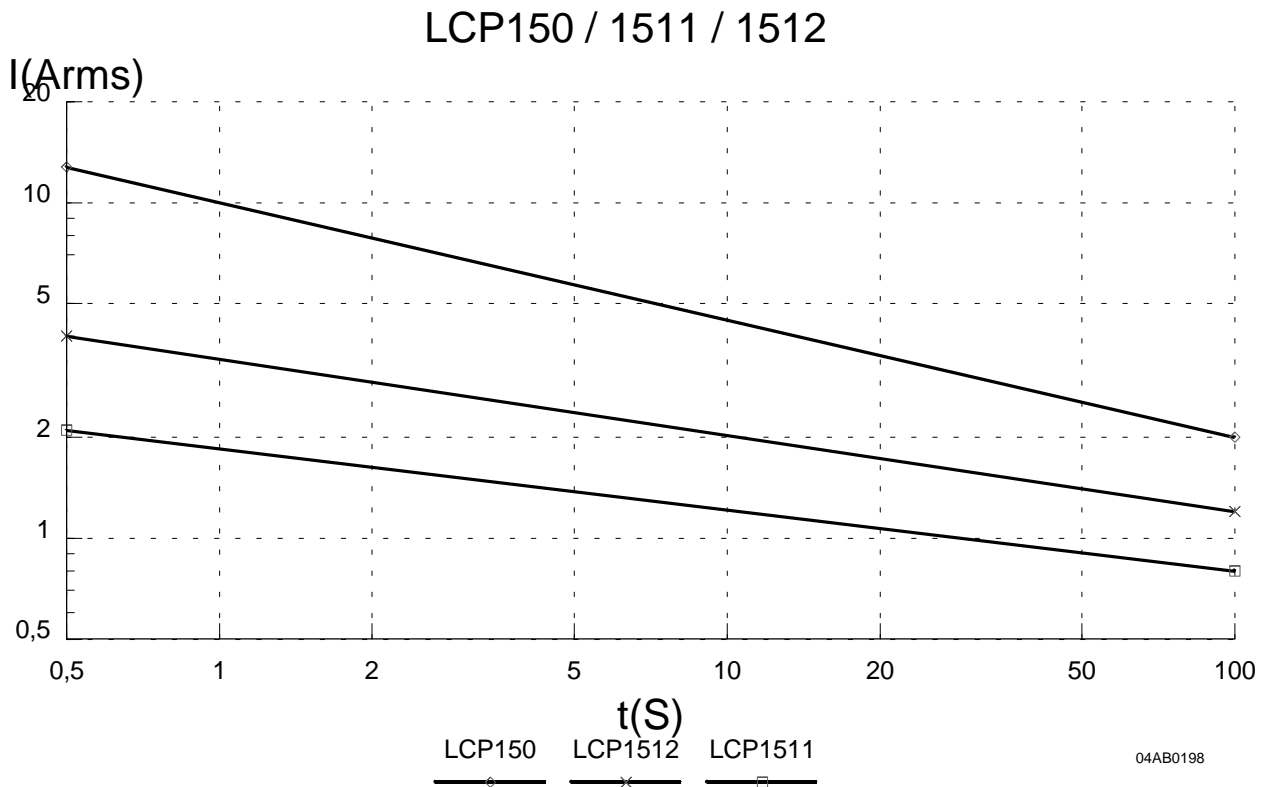

CONCLUSION

The devices in the LCPxxx family have common characteristics, divided into three regions :

- a) Clamping mode, still functional after 15 minutes
- b) Crowbar mode (firing) still functional after 15 minutes of test at 25°C

c) Crowbar mode, with a destruction time defined by figure 4.

The given curves enable the appropriate series elements to be chosen, for example a PTC device.

Information furnished is believed to be accurate and reliable. However, SGS-THOMSON Microelectronics assumes no responsibility for the consequences of use of such information nor for any infringement of patents or other rights of third parties which may result from its use. No license is granted by implication or otherwise under any patent or patent rights of SGS-THOMSON Microelectronics. Specifications mentioned in this publication are subject to change without notice. This publication supersedes and replaces all information previously supplied.

SGS-THOMSON Microelectronics products are not authorized for use as critical components in life support devices or systems without express written approval of SGS-THOMSON Microelectronics.

© 1995 SGS-THOMSON Microelectronics - Printed in Italy - All rights reserved.

SGS-THOMSON Microelectronics GROUP OF COMPANIES
Australia - Brazil - France - Germany - Hong Kong - Italy - Japan - Korea - Malaysia - Malta - Morocco
The Netherlands - Singapore - Spain - Sweden - Switzerland - Taiwan - Thailand - United Kingdom - U.S.A.